

# SPT AOD VB R&R Instructions

Read completely before starting project. The safety measures outlined in any off-the-shelf DIY mechanics manual should be observed before you proceed (ie. Jack stands, wheel chocks, etc) A specific manual for your vehicle will have more in depth R&R instructions than provided here.



## Tools Required:

- 1) 10mm socket
- 2) 8mm socket
- 3) Snap ring pliers

- 4) Vaseline / ATF lube
- 5) 12 quarts of preferred choice ATF, or, Mercon/Dex III
- 6) Torque wrench (10ft or 100in min)
- 7) Rags and scrapping tools.

## Step 1 - DRAIN

**Traditional Method:** Position drain-pan to rear of transmission pan. Remove pan bolts starting at the rear, up both sides to the point fluid starts to drain from the loosened pan. Once stopped draining, carefully continue to remove all pan bolts and bring pan down towards your drain-pan. No loose objects should be in pan.

**Alt Method:** Remove return coolant line (AOD-Bottom Line, AODE/4R-Top line) from trans – place a short section of hose onto line draining to catch pan. Start the engine. This will pump 80% of the fluid out of the trans and is often less messy. Kill the engine as soon as you see the stream has stopped. Wait a few minutes and repeat. The transmission is now empty enough to remove. *Dispose of fluid in environmentally responsible manner*  
*If you encounter a loose plastic plug – spinning top in appearance - discard it.*

Remove pan gasket and discard. If gasket material sticks to transmission pan or case, remove all material completely with razor/wire brush. Now is a good time to install a drain plug. They can be found at your local auto parts retailer. **Stash all the VB parts you remove including the pan bolt in the transmission pan during this process so not too lose them.**

## Step 2 – REMOVE FILTER

Carefully remove the oil filter by removing the three (3) filter bolts (8mm). Pull the filter straight down, discard it. Often the filter grommet will remain on the filter stem, discard it. Remove manual lever detent spring.

Remove the 14 oil pan attaching bolts, Oil Pan Gasket

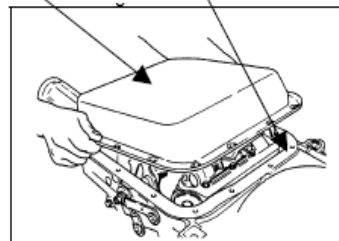

Remove the three oil filter attaching bolts

Filter Attaching Bolts

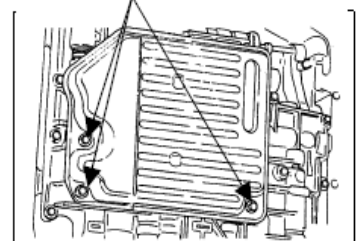

## Step 3 – REMOVE VB

Remove the twenty-four (24) valve body bolts (8mm). Leave one hand tight in center. There are 8 short bolts and 16 long bolts. TWO of the shorter bolts MIGHT be partially threaded – note these bolts for reinstall.

Remove the filter, grommet, and filter gasket.

Oil Filter Grommet Oil filter Gasket



Remove the manual lever detent spring and roller assembly.

Detent spring and roller

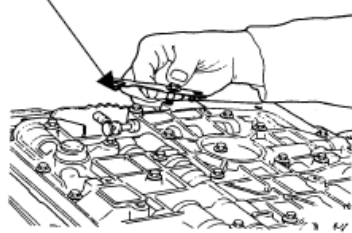

Remove the remaining 24 valve body-to-case attaching bolts, the valve body assembly and the valve body gasket.

NOTE: The four front, one center and the three rear attaching bolts are shorter than the others.

- ◻ Indicated a longer bolt
- Indicates a shorter bolt

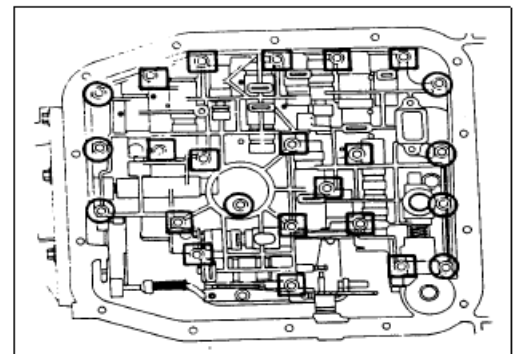

## Setp 3A - 2-3 ACCUMULATOR INSTALL

(Auto shift valve bodies only)

Locate the 2-3 Accum. in pic on next page. Using snap ring pliers remove the accumulator washer/cover. Some 90+ units have the AODE pointed cap retainer and no snap ring, requiring only a screwdriver to remove. A black spring should come down with the cover/cap. The stock 2-3 Accum is usually white plastic or aluminum. Pull down

to remove and discard. Often you will have to use a pair of needle nose pliers or the snap ring pliers to aid in its removal.

Install the supplied rubber bonded accumulator. Lubricate the outside and install small diameter into the case. It is often difficult to install and may take some twisting and force from the pliers/snap ring pliers.

**THE BORE IS AT A SLIGHT ANGLE! It is not 90 degrees of case surface.** You will know it is installed correctly when you can turn it with the pliers in the bore smoothly. Reinstall the spring/cover/snap ring. If you have the cap, the pads on the outside diameter might need to be bent slightly to hold the assembly in place unit VB is secure. **Be sure the pointed side of the cap points down toward the vb.**

#### Step 4 - VB INSTALL

**\*NOTE 2\*** If your vb is not supplied with a case to valve body gasket **DO NOT INSTALL ONE.** Due to the poor quality of gaskets available, SPT has tested and approved the installation of the VB without the gasket.

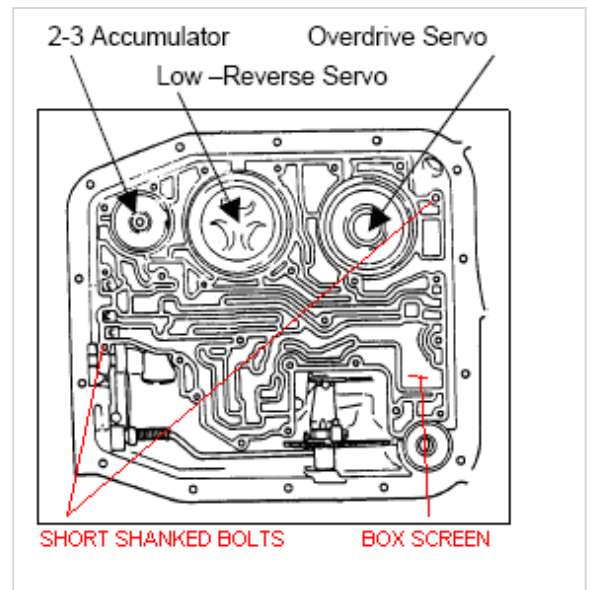

On 1988 and newer reinstall the box shaped filter screen in the case passage with Vaseline as an adhesive. Lift VB into place, sure to engage the manual valve with the rooster comb knob in the OUTERMOST slot in the valve. Stroke the TV valve plunger with your finger as you maneuver the VB into place to allow the TV lever to engage. Once everything is aligned and nothing is binding, insert the two (2) short shanked corner bolts mentioned earlier in outermost drivers side rear and passenger side front.

Reinstall the remaining twenty-two (22) bolts, paying attention to the long and short bolt locations. Tighten the bolts to 7-10 foot/pounds (84-120in pounds) working from the middle of the valve body out. Using the new filter gasket, attach and tighten the filter to 7-8 foot/pounds. **DO NOT OVERTIGHTEN BOLTS.** Best results are around 100inch lbs.

Reinstall the oil pan using the supplied gasket. Tighten the bolts to 6-10 foot/pounds. Refill the transmission in a known fashion. Recommend fill with 4 quarts, start engine, continue fill to full. **DO DO NOT OVERFILL TRANSMISSION!** After first road test recheck transmission for leaks and proper fluid level.

**NOTE:** Make sure the manual and throttle levers are properly positioned before installing the valve body attaching bolts

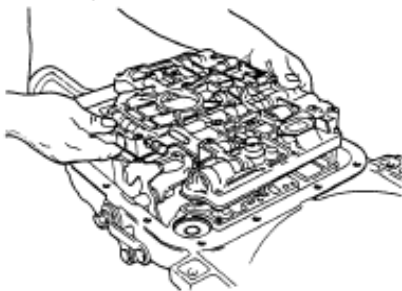

Loosely install 22 valve body attaching bolts using an 8mm socket. Starting at the center and working outward tighten the bolts to 9-11 N.m. (80-100 lb-in.).

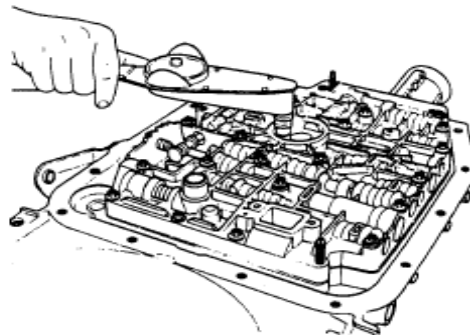

#### AOD TV PRESSURE SETTING

The T.V. linkage and pressure adjustment is critical to proper operation and service life of your AOD. If you experience shift malfunctions they may very well be related to your T.V. system adjustments. Consult a comprehensive AOD transmission manual for the proper adjustment procedures for your vehicle.

With SPT valve bodies, it is safe to set the TV pressure so there is no slack at idle

- 1) On a stock VB or any shift kit modified VB I recommend 5-11 psi at idle or @ 1000 RPM - hot.
- 2) With gauge tool – install in throttle linkage (5/16" rod in throttle stop) set pressure to 35 psi – hot
- 3) WOT TV should be around 90 psi

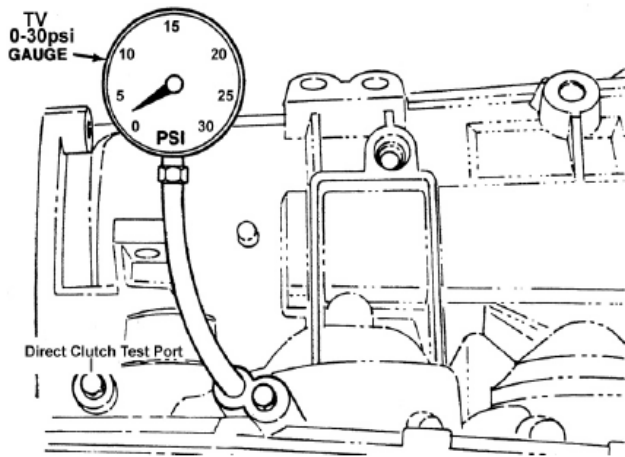

1A: TV/Direct Clutch Test Port Locations

### **WOTS System, SPT-1, SPT-R, SPT-MAC, SPT-MAC-TB**

If your valve body is equipped with the WOTS system or is one of the alternate VB's listed, please read the additional supplement before any work is done.

### **BUZZING SOUND AT IDLE – Constant pressure valve bodies**

This buzz is known as TV BUZZ, a common complaint about the AOD up to around 1989. After 89 the gasket was revised to allow a small amount of back pressure to the tv circuit. With constant pressure valve bodies this feature must be eliminated and the buzz may exist. Adjusting the tv cable and/or idle speed will affect the sound. The buzz is directly related to the AOD gear rotor pump impulses.

-----  
Please note any SUPPLEMENTS to this manual for alternate SPT Valve bodies.

All AOD valve bodies are tested prior to shipment to ensure proper pressure and function. Auto shifting valve bodies are calibrated using the specs you provided regarding. Shift rpms are not an exact science. There are many factors that affect shift RPM between each valve body and its application. SPT's experience and patience is the key to making this the best for your application.

Be cautious to keep work area clean and the components clean for installation.

If your transmission is showing signs of weakness (e.g. burnt fluid, excessive slippage, erratic operation or other indications of mechanical failure), this valve body will not cure the transmissions problems. In fact installation of this kit will probably only worsen the problem due to demand in an increase in the performance of the internals of a weak transmission. This valve body is designed to reduce slippage, increase life of transmission, and increase performance of the shift overlap and some lubrication aspects. However it can not replace any lost friction material or fix any internal issues.

Warranty is only valid for use on normal operating known good transmissions.

All instructions must be followed correctly. Any deviation may result in default of warranty.

Installation within 30 days is recommended to prevent sticking valves. If a period of long storage is predicted, please ensure the VB is kept in a clean area away from electromagnetic source to prevent corrosion of the steel valve to the aluminum casting which may exacerbate the potential for sticking valves.

<p>Dan Gilsdorf Silverfox Performance Transmission 18212 S Walker Est Rd Pleasant Hill, MO 64080 816-365-6215</p>
---